

Situs: 1966 CLEMATIS ST SARASOTA 34239

0100 Single Family Detached

| Building Characteristics | | | |
|--------------------------|------------|-----|--------|
| Category | Type | % | Mult. |
| Exterior | WOOD SIDNG | 100 | 1.0100 |
| Roof | HIP ROOF | 100 | 1.0100 |
| GulfBay | MAINLAND | 100 | 1.0000 |
| Floors | WOOD - | 100 | 1.0000 |
| Foundation | CONC. SLAB | 100 | 1.0000 |
| Roof Material | ASPHALT OR | 100 | 1.0000 |
| Frame | WOOD | 100 | 0.9650 |
| Interior Wall | PLASTER | 70 | 0.7070 |
| Interior Wall | PANEL OR | 30 | 0.2970 |
| Floors | | 0 | 0.0000 |
| Arch Style | OLD | 100 | 0.0000 |
| Wall Height | WH | 100 | 1.0000 |
| Size Index | SZ | 100 | 1.0580 |
| Quality Adj. | QA | 100 | 0.9400 |

Total Adjustments 0.9829

| SAR | Area | H | Rate | Cost New |
|-----|-------|---|-------|----------|
| MLA | 1,303 | X | 79.07 | 103,028 |
| AGA | 280 | | 27.68 | 7,750 |
| UTL | 126 | | 32.63 | 4,111 |
| OPA | 70 | | 20.33 | 1,423 |

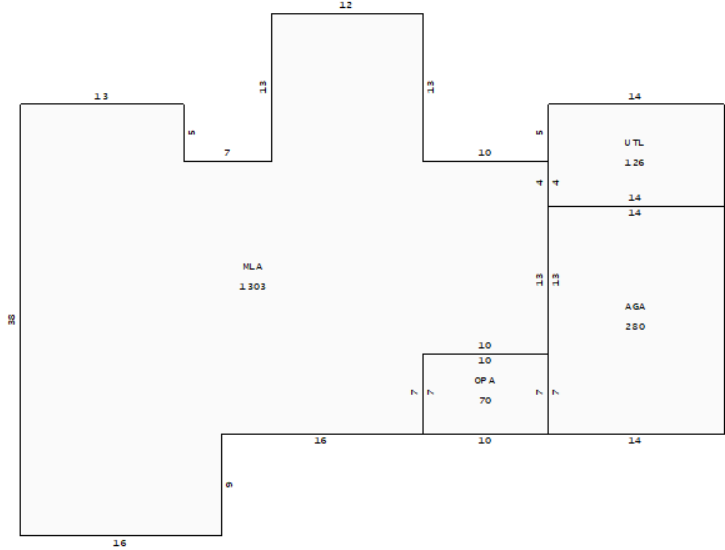

Sketch by Apex Sketch v9 Pro™

Gross Area: 1,779

Net/Living Area: 1,303

Building: 1 of 1

| Category | Units | Cost New |
|-------------------|-------|----------|
| Bathrooms | 2.00 | 5,000 |
| Bedrooms | 2.00 | 0 |
| Living Units | 1.00 | 0 |
| Rooms | 6.00 | 0 |
| Number of Stories | 1.00 | 0 |
| Half Baths | 0.00 | 0 |
| Kitchens | 1.00 | 0 |
| Wall Height | 8.00 | 0 |
| Extra Fixtures | 0.00 | 0 |

| | |
|-----------------------------|---------|
| Total Replacement Cost New: | 120,882 |
| Less Total Depr: 84.00% | 101,541 |
| Building Value: | 19,341 |
| Depreciation Adj. Adj. | |
| Average Condition | 84.00% |

| Grade | Description | Nbhd Factor | Mkt Area Factor |
|-------|-------------|-------------|-----------------|
| 25 | Res Below | 0.9300 | 0 |

| AYB | EYB | DT | % Good | Last Inspection |
|------|------|----|--------|-----------------|
| 1952 | 1982 | 13 | 16.00% | 04/21/2020 738 |

| # | Instrument | Transfer Date | Consideration | Type | QC | QC Description | V/I | Grantor |
|---|------------|---------------|---------------|------|----|----------------|-----|---------|
| 1 | 1979/893 | 09/01/1987 | \$56,000 | NA | 01 | Sale qualified | I | |

| # | Code | Description | B# | Qty | Length | Width | Units | Unit Price | Grade | Cond | AYB | EYB | % Depr | Value | Notes |
|---|------|-------------|----|-----|--------|-------|----------|------------|-------|------|-----|-----|--------|-------|-------|
| 1 | MLND | Main Land | | | | | 9,000.00 | SD | | | | | | | |

| # | Land Type | Land Type Description | Land Use | Units | Unit Type | Base Unit Price | Nbhd Factor | Mkt Factor | Land Influences | | | | | | Adj. Unit Price | Land Value |
|---|-----------|-----------------------|----------|----------|-----------|-----------------|-------------|------------|-----------------|------|------|------|------|------|-----------------|------------|
| | | | | | | | | | Code | Fact | Code | Fact | Code | Fact | | |
| 1 | MLND | Main Land | NA | 9,000.00 | SD | 42.00 | 1 | | LC | 0.85 | | | | | 38.87 | 349,860 |

| Parcel Notes | | | |
|--------------|-----------|--------|---|
| 25 | Res Below | 0.9300 | 0 |

SARASOTA COUNTY PROPERTY APPRAISER
PROPERTY RECORD CARD

| VALUE SUMMARY | CURRENT | PRIOR YEAR |
|-------------------------|-------------------|-------------------|
| Building Value | \$ 19,300 | \$ 20,100 |
| Extra Feature Value | \$ 0 | \$ 0 |
| Land Value - Market | \$ 349,900 | \$ 370,700 |
| Land Value - Ag | \$ 0 | \$ 0 |
| TOTAL JUST VALUE | \$ 369,200 | \$ 390,800 |

| Values pertaining to County Assessment | | |
|----------------------------------------|------------|------------|
| Assessed Value | \$ 263,477 | \$ 257,553 |
| Exemption Codes | 910 999 | 910 999 |
| Exemption Amount | \$ 50,000 | \$ 50,000 |
| Taxable Value | \$ 213,477 | \$ 207,553 |

| PARCEL DATA | | | | |
|-------------|---------|------|----------|--------|
| Mkt Area | Nbhd | Sub | Lot SqFt | Zoning |
| 604 | 6442.00 | 0270 | 9,000 | RSF3 |

| | |
|------------|------------------------|
| Sub Name: | DESOTA PARK |
| Bldg Type: | Single Family Detached |

| CONDOMINIUM INFORMATION | | | |
|-------------------------|--------------|--------|------|
| Floor # | Total Floors | Unit # | View |
| | | | |

| Permit Information | | | |
|--------------------|------------|------|-------------|
| Number | Date | Cost | Description |
| 20092412 | 05/06/2009 | 0 | |